

# Tuning the activity of an enzyme for unusual environments: Sequential random mutagenesis of subtilisin E for catalysis in dimethylformamide

(peptide synthesis/biocatalysis/molecular evolution/serine protease)

KEQIN CHEN AND FRANCES H. ARNOLD\*

Division of Chemistry and Chemical Engineering, 210-41, California Institute of Technology, Pasadena, CA 91125

Communicated by Peter B. Dervan, March 19, 1993 (received for review September 2, 1992)

**ABSTRACT** Random mutagenesis has been used to engineer the protease subtilisin E to function in a highly nonnatural environment—high concentrations of a polar organic solvent. Sequential rounds of mutagenesis and screening have yielded a variant (PC3) that hydrolyzes a peptide substrate 256 times more efficiently than wild-type subtilisin in 60% dimethylformamide. PC3 subtilisin E and other variants containing different combinations of amino acid substitutions are effective catalysts for transesterification and peptide synthesis in dimethylformamide and other organic media. Starting with a variant containing four effective amino acid substitutions (D60N, D97G, Q103R, and N218S; where, for example, D60N represents Asp-60 → Asn), six additional mutations (G131D, E156G, N181S, S182G, S188P, and T255A) were generated during three sequential rounds of mutagenesis and screening. The 10 substitutions are clustered on one face of the enzyme, near the active site and substrate binding pocket, and all are located in loops that connect core secondary structure elements and exhibit considerable sequence variability in subtilisins from different sources. These variable surface loops are effective handles for “tuning” the activity of subtilisin. Seven of the 10 amino acid substitutions in PC3 are found in other natural subtilisins. Great variability is exhibited among naturally occurring sequences that code for similar three-dimensional structures—it is possible to make use of this sequence flexibility to engineer enzymes to exhibit features not previously developed (or required) for function *in vivo*.

With exquisite substrate specificities and high reaction selectivities, enzymes offer tremendous advantages for chemical synthesis. Nonetheless, practical applications of enzyme catalysis have been limited, due in large part to relatively poor stabilities and catalytic activities under the conditions that characterize industrial processes: high temperatures, extremes of pH, or nonaqueous solvents. Enzymes evolved for the survival benefit of an organism may not exhibit features essential for *in vitro* application.

A large body of experience in tailoring enzyme properties by making selected substitutions of the enzyme's amino acid sequence has accumulated. A “rational design” approach involving site-directed mutagenesis is inefficient, however, in the absence of detailed structural information or when the molecular basis for the property of interest is poorly understood. In such cases, random mutagenesis combined with selection or screening can be a useful alternative for generating both the desired improvements and a data base for future rational approaches to protein design. Random mutagenesis has been used to enhance or alter various enzyme features, including thermal stability (1–3), alkaline stability (4), and substrate specificity (5), and to recover the catalytic

activity of an enzyme damaged by site-directed mutagenesis (6).

We have used random mutagenesis and screening to identify amino acid substitutions that recover the catalytic activity lost by the serine protease subtilisin E in polar organic solvents. In addition to the obvious advantage of enhancing the solubilities of organic substrates, organic solvents can lead to unusual chemistry when enzyme-catalyzed reactions that are infeasible in an aqueous medium become favored in a nonaqueous one (7). In organic solvents, serine proteases are promising catalysts for organic synthesis and the preparation of unusual polymers (8–11). A triple variant of subtilisin E with enhanced activity in dimethylformamide (DMF) was described in an earlier report (12). Here we report a variant containing 10 amino acid substitutions that was generated by sequential rounds of random mutagenesis and screening for increased activity in DMF. The nature and locations of these amino acid substitutions should provide useful information for designing enzymes to function in polar organic solvents.

Mutagenesis experiments indicate that only a fraction of the amino acid residues in a protein are critical for function, folding, and stability (13, 14). Furthermore, there is great variability among naturally occurring sequences that code for similar three-dimensional structures. We wish to exploit this sequence flexibility to “tune” enzymes to exhibit features not previously developed (or required) for function *in vivo*—in this case, catalysis in an unusual environment. With sequential random mutagenesis and screening for the property of interest, effective amino acid substitutions can be accumulated in an approach that partially mimics the natural evolutionary refinement process.

## MATERIALS AND METHODS

**Site-Directed Mutagenesis.** Site-directed mutagenesis was carried out on an 800-bp *HindIII/BamHI* fragment from plasmid pKWC containing the gene for subtilisin E (12) by a modified PCR technique. For each substitution, an oligonucleotide containing the desired mutation was used as the primer (mismatch primer) to initiate chain extension between the 5' and 3' PCR primers used for random mutagenesis (12). In the first PCR, the mismatch primer and the 5' primer were used to generate a DNA fragment containing the new base substitution. The fragment was separated from the primers by agarose gel electrophoresis, purified, and used as the new 5' primer in a second PCR with the 3' primer to generate the desired 800-bp *HindIII/BamHI* DNA fragment. The subtilisin gene for the 4M variant was created by adding a fourth mutation coding for the amino acid substitution Asp-97 →

The publication costs of this article were defrayed in part by page charge payment. This article must therefore be hereby marked “advertisement” in accordance with 18 U.S.C. §1734 solely to indicate this fact.

Abbreviations: DMF, dimethylformamide; sAAPPF-pna, succinyl-Ala-Ala-Pro-Phe-*p*-nitroanilide; DP, degree of polymerization. \*To whom reprint requests should be addressed.

Gly (D97G) to the triple variant (3M) (D60N + Q103R + N218S) (12).

**Random Mutagenesis.** The *HindIII/BamHI* DNA fragment encoding mature 4M subtilisin E from amino acid residue 49 to the C terminus was used as the template for the first round of random mutagenesis by PCR. Modifications in the PCR conditions (12, 15) were made to increase the frequency of mutations: a 100  $\mu$ l reaction mixture contained 10  $\mu$ l of 10 $\times$  PCR buffer, 1  $\mu$ l of 1 M  $\beta$ -MeOH; 15  $\mu$ l of dimethyl sulfoxide; 10  $\mu$ l of 5 mM MnCl<sub>2</sub>; 10  $\mu$ l each of 10 mM dGTP, dCTP, and dTTP; 5  $\mu$ l of 2 mM dATP; 1.5  $\mu$ l each of the 5' and 3' primers (0.4 mg/ml); 0.1  $\mu$ g of template DNA; and 0.5  $\mu$ l of *Taq* polymerase (5 units/ $\mu$ l; Perkin-Elmer/Cetus). PCR was carried out at 94°C for 1 min, 42°C for 2 min, and 72°C for 3 min, and a total of 45 cycles were performed. The last chain-extension reaction was at 72°C for 7 min. The size and yield of the amplified DNA fragments were determined by agarose gel electrophoresis. Plasmid construction, transformation of *Bacillus subtilis* DB428, screening for enhanced activity in the presence of DMF, and enzyme purification were carried out as described (12).

**Enzyme Kinetics.** Amidase activities were measured on peptide substrates succinyl-Ala-Ala-Pro-Phe-*p*-nitroanilide (sAAPF-pna) or succinyl-Ala-Ala-Pro-Met-*p*-nitroanilide (sAAPM-pna) in 0.1 M Tris-HCl, pH 8.0/10 mM CaCl<sub>2</sub> at 37°C (12).

**Subtilisin-Catalyzed Peptide Synthesis.** L-Methionine methyl ester hydrochloride (150 mg) and  $\approx$ 250  $\mu$ g of enzyme were added to a 1-ml reaction solution containing 60% or 70% DMF and 75  $\mu$ l of triethylamine. The reaction was carried out on a rotator at room temperature for 24–48 h. The precipitate was collected by centrifugation, washed with water, and dried.

## RESULTS

**Sequential Mutagenesis.** Subtilisin E (4M) contains four amino acid substitutions that were generated separately by random mutagenesis and subsequently combined in a single variant (Table 1). To further improve the enzyme's activity in polar organic solvents, 4M was subjected to sequential random mutagenesis and screening. Active subtilisin secreted from the bacterial cells will hydrolyze casein, creating visible halos on agar plates containing 1% casein. The secreted enzyme can be picked up on a nitrocellulose filter and transferred to DMF-containing plates to screen for activity in DMF without damaging the *B. subtilis* host (12). Plasmid DNA was isolated from a clone whose enzyme produced a halo larger than those surrounding the wild-type and 4M controls on a 35% DMF/casein plate. At the end of each mutagenesis and screening step, the clone producing the largest halo on DMF/casein plates was isolated and used as the template for the next random mutagenesis reaction. After the third cycle, the enzyme from a single clone, PC3 (D60N + D97G + Q103R + G131D + E156G + N181S + S182G + S188P + N218S + T255A), produced a considerably larger halo on casein plates containing 35% DMF and also exhibited greater activity toward hydrolysis of sAAPF-pna in 40%

DMF when compared to 4M. In all,  $\approx$ 4000 colonies were screened.

The PCR random mutagenesis technique generates DNA base substitutions distributed throughout the targeted region of the subtilisin gene (data not shown). Of 16 base substitutions generated during the three sequential mutagenesis cycles, 6 resulted in amino acid replacements: G131D, E156G, N181S, S182G, S188P, and T255A. Since the PCR conditions have been modified by introducing dGTP and dATP at a 10/1 ratio, most of the base substitutions are transitions, A to G or T to C (due to the base substitutions occurring on the complementary strand). Further modifications in the PCR conditions to generate both transition and transversion mutations would significantly increase the frequency and range of possible amino acid substitutions.

**Subtilisin Variants Exhibiting Improved Catalytic Activity in DMF.** Kinetic parameters for the purified subtilisin E variants are reported in Table 1. The three cycles of random mutagenesis and screening resulted in a 3-fold improvement in catalytic efficiency over 4M in 40% DMF. (In purely aqueous solution, PC3 has the same catalytic efficiency as 4M.) PC3 subtilisin is 130 times more efficient than wild-type subtilisin E in 40% DMF. The improvement is a result of a decrease in the Michaelis constant  $K_m$  (by a factor of 7) as well as an increase in the catalytic rate constant  $k_{cat}$  (by a factor of 19).

The effects of amino acid substitutions on catalytic efficiency can also be quantified in terms of the incremental free energy of transition state stabilization of the mutant relative to wild type  $\{\Delta\Delta G^\ddagger = -RT \ln[(k_{cat}/K_m)_{mutant}/(k_{cat}/K_m)_{wild\ type}]\}$ , values of which are given in Table 1. In 40% DMF, the combined effect of the amino acid substitutions in PC3 is to lower the free energy of the transition state (relative to wild type) by 3.0 kcal/mol (1 cal = 4.184 J). Thus, a large fraction of the transition state stabilization lost upon transferring wild-type subtilisin E to 40% DMF (3.4 kcal/mol) has been recovered in PC3.

The catalytic efficiency of PC3 subtilisin E toward hydrolysis of the peptide substrate sAAPM-pna was determined in DMF concentrations up to 85%. (The enzyme is soluble over this entire range.) As shown in Fig. 1, the PC3 variant is more active even in very high concentrations of the organic solvent:  $k_{cat}/K_m$  is 256 times that of wild type in 60% DMF and 131 times higher in 85% DMF.

**Effects of Single Amino Acid Substitutions on Catalytic Activity.** To investigate the effects of the individual amino acid replacements on subtilisin activity in the presence of DMF, all 10 single variants corresponding to the amino acid substitutions in PC3 were constructed by site-directed mutagenesis. The individual amino acid substitutions vary in their effects on amide hydrolysis in aqueous buffer and in the presence of 20% DMF, as shown in Table 2. Although G131D improves  $k_{cat}$  in both the presence and absence of DMF, its effect on  $K_m$  is such that catalytic efficiency is enhanced only in the organic solvent. In fact, G131D is slightly less efficient than wild type in purely aqueous media ( $\Delta\Delta G^\ddagger = +0.09$  kcal/mol vs.  $-0.43$  kcal/mol in 20% DMF). The single

Table 1. Kinetic parameters  $k_{cat}$ ,  $K_m$ ,  $k_{cat}/K_m$  and free energies of transition state stabilization ( $\Delta\Delta G^\ddagger$ ) for hydrolysis of sAAPF-pna by subtilisin E variants in 0.1 M Tris-HCl/10 mM CaCl<sub>2</sub>, pH 8.0, containing 0%, 20%, and 40% (vol/vol) DMF at 37°C

	0% DMF				20% DMF				40% DMF			
	$k_{cat}$ , s <sup>-1</sup>	$K_m$ , mM	$k_{cat}/K_m$ , M <sup>-1</sup> s <sup>-1</sup> $\times 10^{-3}$	$\Delta\Delta G^\ddagger$ , kcal·mol <sup>-1</sup>	$k_{cat}$ , s <sup>-1</sup>	$K_m$ , mM	$k_{cat}/K_m$ , M <sup>-1</sup> s <sup>-1</sup> $\times 10^{-3}$	$\Delta\Delta G^\ddagger$ , kcal·mol <sup>-1</sup>	$k_{cat}$ , s <sup>-1</sup>	$K_m$ , mM	$k_{cat}/K_m$ , M <sup>-1</sup> s <sup>-1</sup> $\times 10^{-3}$	$\Delta\Delta G^\ddagger$ , kcal·mol <sup>-1</sup>
Wild type	21	0.56	38	—	17	12.2	1.4	—	3.3	20.9	0.16	—
3M	40	0.11	360	-1.39	63	1.4	44	-2.15	20	2.94	6.8	-2.3
4M	43	0.17	249	-1.17	76	2.4	32	-1.84	41	5.54	7.5	-2.4
PC3	27	0.10	274	-1.22	73	0.7	99	-2.63	62	2.96	21	-3.0

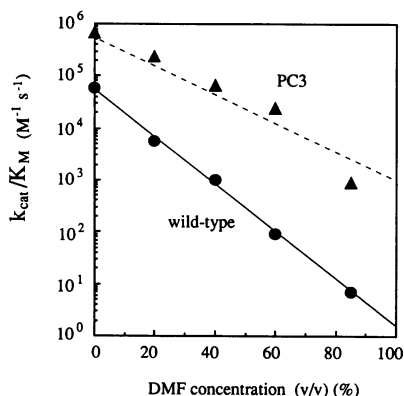

FIG. 1. Catalytic efficiency for hydrolysis of sAAPM-pna by wild-type subtilisin E (●) and PC3 (▲).  $k_{\text{cat}}/K_m$  values were determined from initial rates at low substrate concentrations in 0.1 M Tris-HCl/10 mM CaCl<sub>2</sub>, pH 8.0 at 37°C and specified amounts (vol/vol) of DMF.

substitutions N181S and T255A improve the catalytic efficiency of subtilisin E to the same extent in the absence of DMF as they do in the presence of DMF, and their effect is primarily through a decrease in  $K_m$ . Mutations E156G, S182G, and S188P all decrease  $K_m$  as well. The variants containing these last three single amino acid substitutions, however, exhibit catalytic efficiencies that are essentially the same as wild type in both 0% and 20% DMF because of concomitant decreases in  $k_{\text{cat}}$ . Although E156G, S182G, and S188P by themselves do not enhance activity in the presence of 20% organic solvent, they may be beneficial at higher DMF concentrations. The effects of these mutations in higher concentrations of DMF are difficult to measure, however, because the activities of the single variants are still quite low. Since all three of these substitutions were generated along with N181S in the first mutagenesis and screening cycle, it is also possible that they do not directly affect the catalytic activity of the PC3 enzyme. An alternative explanation for their appearance during the screening process is that all three of these mutations are slightly stabilizing (see below).

**Enzyme Stability in the Presence of DMF.** The kinetics of irreversible deactivation, important for biocatalysis applications, also reflect the thermodynamic stability of subtilisin (16). Residual activities were measured after incubating wild-type, 3M, and PC3 subtilisin E in 70% DMF for up to 460 h. The kinetic stability of PC3 is similar to that of wild-type

subtilisin E (43% of the activity of PC3 remains after 460 h vs. 49% for wild type), while 3M is slightly more stable (63% activity after 460 h). The screening process has identified a set of mutations that enhance the enzyme's catalytic activity in the presence of DMF without compromising its stability.

The effects on stability of the 10 individual amino acid substitutions in PC3 vary, as indicated in Table 2. Of the 6 amino acid substitutions accumulated during the sequential random mutagenesis of 4M, 3 (E156G, S182G, and S188P) stabilize subtilisin E, the largest effect being an increase in the half-life by more than a factor of 2. Although T255A is relatively destabilizing, this effect appears to be canceled out in PC3 by the stabilizing substitutions.

**Peptide Synthesis.** 3M, PC3, and wild-type subtilisin E were used to catalyze the kinetically controlled synthesis of poly(L-methionine) from L-methionine methyl ester. Approximately 15 mg of polymer was produced by 3M and PC3 in 70% DMF, conditions in which no detectable polymer was synthesized by the wild-type enzyme. A unique free methionine peak appeared in the amino acid analysis of hydrolyzed polymer produced by the 3M variant, while no free methionine was detected in an unhydrolyzed sample. The degree of polymerization (DP) was determined by mass spectrometry to be  $\approx 36$  ( $M_r = 4700$ ). In 60% DMF, wild-type subtilisin E can catalyze the polymerization of L-methionine methyl ester to form  $\approx 15$  mg of a polymer of  $M_r$  1000–1500 (DP,  $\approx 10$ ).

## DISCUSSION

**Random Mutagenesis.** There is no guarantee that mutations generated in separate experiments will exhibit cumulative benefits when combined, especially as the accumulating substitutions begin to interact. Therefore, effective mutations were accumulated in sequential cycles of random mutagenesis and screening. With a sequential approach, mutations must contribute positively, in conjunction with the other substitutions already present, in order to appear during screening. A limitation of this sequential engineering approach is that, upon choosing the template for the subsequent cycle of mutagenesis and screening, a single evolutionary pathway or branch is followed. It is possible that the chosen pathway leads prematurely to a dead end, where no further improvements can be made.

Sequential random mutagenesis is operationally efficient because sequencing and detailed characterization of the enzyme variants after each mutagenesis and screening stage

Table 2. Kinetic parameters  $k_{\text{cat}}$ ,  $K_m$ ,  $k_{\text{cat}}/K_m$  and free energies of transition state stabilization ( $\Delta\Delta G^\ddagger$ ) for hydrolysis of sAAPF-pna by single variant subtilisins E in 0.1 M Tris-HCl/10 mM CaCl<sub>2</sub>, pH 8.0, containing 0% and 20% DMF at 37°C

	0% DMF				20% DMF				40% DMF
	$k_{\text{cat}}$ , s <sup>-1</sup>	$K_m$ , mM	$k_{\text{cat}}/K_m$ , M <sup>-1</sup> s <sup>-1</sup> × 10 <sup>-3</sup>	$\Delta\Delta G^\ddagger$ , kcal·mol <sup>-1</sup>	$k_{\text{cat}}$ , s <sup>-1</sup>	$K_m$ , mM	$k_{\text{cat}}/K_m$ , M <sup>-1</sup> s <sup>-1</sup> × 10 <sup>-3</sup>	$\Delta\Delta G^\ddagger$ , kcal·mol <sup>-1</sup>	Half-life,* h
Wild type	21	0.56	38	—	17	12	1.4	—	6
D60N†	22	0.53	42	-0.06	23	7.6	3.1	-0.51	2
D97G†	20	0.27	74	-0.41	21	5.2	4.0	-0.64	4
Q103R†	31	0.25	124	-0.73	18	2.7	6.8	-0.98	6
G131D	39	1.15	33	+0.09	29	10	2.8	-0.43	4
E156G	10	0.25	39	-0.02	12	7.8	1.5	-0.04	15
N181S	27	0.23	120	-0.71	17	3.8	4.4	-0.71	6
S182G	18	0.47	38	0.00	11	8.0	1.4	0.00	7
S188P	19	0.52	37	+0.02	10	6.1	1.6	-0.08	12
N218S†	36	0.45	81	-0.46	ND	ND	3.9	-0.61	9
T255A	7.3	0.14	52	-0.19	5.7	3.1	1.8	-0.17	<10 min

ND, not determined.

\*Half-lives of deactivation were measured in 40% DMF/60% 10 mM Tris-HCl, pH 8.0/2 mM CaCl<sub>2</sub> at 50°C.

†Amino acid substitution in 4M subtilisin E used as template for sequential random mutagenesis.

are not necessary. A further important advantage is that the screening can take place under progressively harsher conditions. Even though the ultimate goal of this random mutagenesis exercise was to produce a subtilisin active in very high concentrations of polar organic solvents, the activity of the wild-type enzyme is simply too low to allow for rapid and efficient screening in DMF concentrations higher than 20–30%. Four effective amino acid substitutions (4M variant) allowed the use of 35% DMF in the casein screening plates compared to 27% used to identify single mutations in the wild-type enzyme (12). And, while the effects of single mutations on hydrolysis of the specific peptide substrates could be conveniently assayed in only 20% DMF, the concentration could be increased all the way to 60% for rapid assays of PC3. A further 10-fold improvement in activity would allow screening to be carried out in 80% DMF, and it is not inconceivable that screening could eventually be carried out in 100% DMF.

**Effective Mutations Are Located in the Variable Loops Around the Active Site, and Most Are Found in Other Natural Subtilisins.** All the amino acid substitutions found to influence catalytic activity in DMF are located at the surface of the protein and are clustered in a region that encompasses the active site and substrate binding pocket (Fig. 2). D60N, D97G, and E156G are very close to the amino acid residues critical to catalysis, while D97G, Q103R, E156G, and N218S are located in or very close to the substrate binding pocket.

Siezen and coworkers (17) have compared the amino acid sequences of >40 subtilisins from different sources. These sequences show a conserved core three-dimensional structure with insertions and deletions that are preferentially confined to surface loops. As shown schematically in Fig. 3, the  $\alpha$ -helix and  $\beta$ -sheet structures are relatively conserved in their sequences, while the sequences of the peptide loops that connect the core secondary structures are very often variable. Of the 10 amino acid substitutions in PC3 subtilisin E, not one is found in the conserved core  $\alpha$ -helix or  $\beta$ -sheet structures; they are all located in the loops that interconnect the core secondary structures. All the affected loops lie on one face of the enzyme, surrounding the active site.

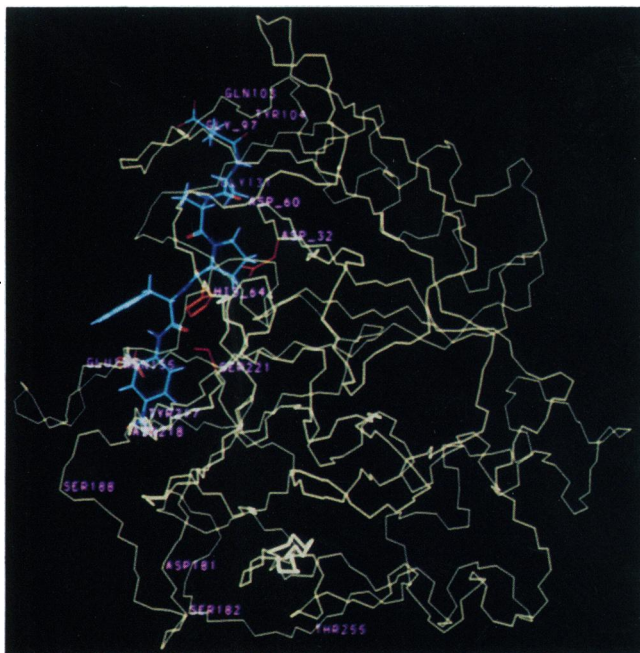

FIG. 2. Subtilisin structure showing bound substrate sAAPF-pna and locations of 10 amino acid substitutions in PC3 subtilisin E (structure is that of subtilisin BPN').

Although base substitutions are randomly distributed throughout the targeted subtilisin gene sequence, those that lead to amino acid substitutions that are effective in enhancing catalytic activity have been limited to specific regions of the enzyme. The variable surface loops near the substrate pocket and active site appear to be effective handles for tuning the activity of subtilisin. This information can be used to develop more rational mutagenesis strategies. For example, one could direct more intensive mutagenesis to a much smaller set of amino acid residues located in these surface loop segments.

Seven of the 10 amino acid substitutions in PC3 subtilisin E are found in at least 3 other members of the subtilisin family. The remaining three (Q103R, S182G, and T255A) are not found in the 36 subtilisins whose sequences have been compared (17). The destabilizing influence of Ala-255 (Table 2) may explain why it is not found in other subtilisins. Although no natural subtilisin contains more than 3 of the 10 amino acid replacements in PC3, PC3 subtilisin E is not an entirely new enzyme. It can be thought of as a mix and match of amino acids from different, naturally occurring enzymes.

**Effects of DMF and Amino Acid Substitutions on Catalytic Efficiency of Subtilisin E.** Although polar organic solvents are excellent media for many chemical transformations, these solvents often drastically reduce both the stability and activity of enzymes. The multiple, competing noncovalent interactions that both stabilize the folded enzyme and determine its ability to stabilize a reaction transition state are influenced by the surrounding solvent. Solvent also affects the partitioning of the substrate to the enzyme's substrate binding pocket.

DMF dramatically reduces the catalytic efficiency of subtilisin E, as can be seen from the kinetic data for the wild-type enzyme in Table 1. A small amount of polar organic solvent (20%) causes a large increase in  $K_m$  (22-fold) while having relatively little effect on  $k_{cat}$ . Effects on  $k_{cat}$  become pronounced at DMF concentrations around 40%. Increasing the concentration of DMF over a wide range causes a steady loss

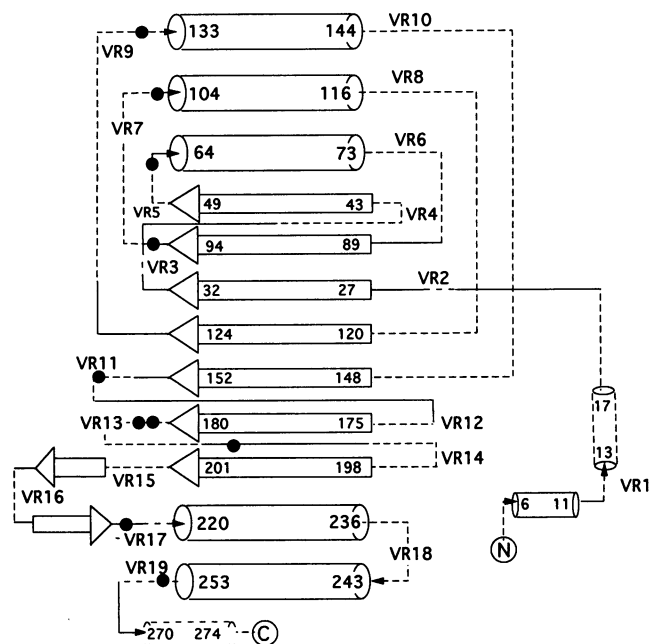

FIG. 3. Schematic representation of the secondary structure topology of subtilisin.  $\alpha$ -Helices are represented as cylinders and  $\beta$ -sheets are indicated by arrows. Solid lines indicate conserved regions in all subtilisins. Dashed lines indicate variable regions (VRs) (from ref. 17). ●, Locations of amino acid substitutions in PC3 subtilisin E.

of catalytic efficiency, such that  $k_{\text{cat}}/K_m$  drops by 4 orders of magnitude in 85% DMF (Fig. 1). A significant portion of this loss is recovered in the PC3 variant, whose activity in 85% DMF is only 69 times less than the wild type in water. The  $k_{\text{cat}}$  of PC3 actually increases in 20% DMF, and its  $K_m$  is much less sensitive to the organic solvent (7-fold increase in 20% DMF) than the wild-type  $K_m$ .

A very large increase in the amidase activity over a wide range of DMF concentrations has been achieved in PC3 subtilisin E. Although this enzyme is somewhat more active than wild-type in purely aqueous buffer (mainly due to improved substrate specificity), this increase is considerably more pronounced in the presence of DMF. In 60% DMF, PC3 is 256 times more efficient than the wild-type enzyme and only 3-fold less efficient in 60% DMF than the wild type is in water.

**Effects of the Mutations Are Not Additive.** The effects of mutations on activity and stability in nonaqueous solvents should be additive in the absence of interactions among substituted amino acids. This was found to be the case for the three mutations in the 3M triple variant, which stabilize the reaction transition state by an amount equal to the sum of the effects of the individual substitutions (12). The 10 amino acid substitutions in the PC3 variant, however, are not additive. For example, the sum of the incremental free energies of transition state stabilization ( $\Delta\Delta G^\ddagger$ ) for the six additional mutations added to 4M is  $-1.43$  kcal/mol in 20% DMF (Table 2). The free energy of transition state stabilization of PC3, however, decreases by only 0.79 kcal/mol compared to 4M (Table 1). Therefore, the 6 amino acids interact to the extent that almost half the effect of the individual substitutions is lost when the mutations are combined. The sum of the  $\Delta\Delta G^\ddagger$  values for all 10 substitutions in PC3 is  $-4.17$  kcal/mol in 20% DMF. However, when combined in PC3 the net transition state stabilization from the amino acid substitutions is only  $-2.63$  kcal/mol. This loss of additivity is not surprising since the 10 amino acid replacements in PC3 are clustered around the active site and substrate binding pocket.

**Synthetic Activity in Organic Solvents.** Obtaining high catalytic activity in organic solvents is useful for several applications in chemical synthesis. For example, in organic solvents subtilisin can catalyze the stereoselective acylation of racemic amines with a methacrylate ester to yield optically active monomers (7). Subtilisin can also acylate sugars (18) and steroids (8) regioselectively and will catalyze peptide synthesis either by direct reversal of the hydrolytic process or by aminolysis of N-protected amino acid or peptide esters (19).

The subtilisin variants obtained by screening for enhanced amidase activity in the presence of DMF are also more active than wild-type subtilisin E in the hydrolysis of amino acid esters in the presence of organic solvents (data not shown). The 3M variant has been used in transesterification of *N*-acetyl-L-phenylalanine methyl ester in three organic solvents containing very little water (20). 3M subtilisin E is considerably more efficient than wild type in all three solvents: a 43-fold enhancement in catalytic efficiency was observed in anhydrous hexane and in hexane containing a small amount of water. The improvement is 10-fold in acetonitrile (0.1% water). The experiments reported here show that PC3 and 3M subtilisin E can catalyze the synthesis of poly(L-methionine) under conditions in which the wild-type enzyme has no measurable peptide synthesis activity (70% DMF). 3M forms a longer polymer (DP,  $\approx 36$ ) in 70% DMF than can be formed in lower solvent concentrations (DP,  $\approx 10$  in 60% DMF), and the reaction proceeds much more quickly than the corre-

sponding reaction with the wild-type enzyme. Thus, these engineered subtilisin variants offer several advantages: (i) the concentration of enzyme needed to perform a given reaction can be greatly reduced, (ii) the reaction can be completed more quickly, and (iii) because the engineered enzymes can tolerate solvent environments that inactivate the wild-type enzyme, new products can be obtained.

## CONCLUSIONS

A significant fraction of the catalytic activity lost by subtilisin E in the presence of DMF has been recovered by accumulating 10 effective mutations in surface loops surrounding the active site and substrate binding pocket. The resulting PC3 subtilisin is almost as efficient in 60% DMF as the wild-type enzyme is in water; PC3 also exhibits unique synthetic capabilities. This result was achieved despite the fact that the PCR mutagenesis technique can access only a limited subset of all possible amino acid substitutions. Initial solutions to the problem of low subtilisin activity in DMF were not rare: between 6 and 9 effective substitutions were found by screening only a few thousand colonies. There is clearly considerable potential for engineering enzymes to function in unusual environments.

This research was supported by the Office of Naval Research and the Department of Energy (Advanced Industrial Concepts Division). F.H.A. gratefully acknowledges a Presidential Young Investigator award from the National Science Foundation and a fellowship from the David and Lucile Packard Foundation.

- Bryan, P. N., Rollence, M. L., Pantoliano, M. W., Wood, J., Finzel, B. C., Gilliland, G. L., Howard, A. J. & Poulas, T. L. (1986) *Protein Struct. Funct. Genet.* **1**, 326–334.
- Liao, H., McKenzie, T. & Hageman, R. (1986) *Proc. Natl. Acad. Sci. USA* **83**, 576–580.
- Joyet, P., Declerck, N. & Gaillardin, C. (1992) *Bio/Technology* **10**, 1579–1583.
- Cunningham, B. C. & Wells, J. A. (1987) *Protein Eng.* **1**, 319–325.
- Oliphant, A. R. & Struhl, K. (1989) *Proc. Natl. Acad. Sci. USA* **86**, 9094–9098.
- Hermes, J. D., Blacklow, S. C. & Knowles, J. R. (1990) *Proc. Natl. Acad. Sci. USA* **87**, 696–700.
- Dordick, J. S. (1989) *Enzyme Microb. Technol.* **11**, 194–211.
- Margolin, A. L., Fitzpatrick, P. A., Dubin, P. L. & Klivanov, A. M. (1991) *J. Am. Chem. Soc.* **113**, 4693–4694.
- Riva, S. & Klivanov, A. M. (1988) *J. Am. Chem. Soc.* **110**, 3291–3292.
- Patil, D. R. & Dordick, J. S. (1991) *Macromolecules* **24**, 3462–3463.
- Zhong, Z. & Wong, C. H. (1991) *Biomed. Biochim. Acta* **50**, S9–S14.
- Chen, K. & Arnold, F. H. (1991) *Bio/Technology* **9**, 1073–1077.
- Heinz, D. W., Baase, W. A. & Matthews, B. W. (1992) *Proc. Natl. Acad. Sci. USA* **89**, 3751–3755.
- Poteete, A. R., Rennell, D. & Bouvier, S. E. (1992) *Protein Struct. Funct. Genet.* **13**, 38–40.
- Saiki, R. K., Gelfand, D. H., Stoffel, S., Scharf, S. J., Higuchi, R., Horn, G. T., Mullis, K. B. & Erlich, H. A. (1988) *Science* **239**, 487–491.
- Pantoliano, M. W., Whitlow, M., Wood, J. F., Dodd, S. W., Hardman, K. D., Rollence, M. L. & Bryan, P. N. (1989) *Biochemistry* **28**, 7205–7213.
- Siezen, R. J., De Vos, W. M., Leunissen, J. A. M. & Dijkstra, B. W. (1991) *Protein Eng.* **4**, 719–737.
- Riva, S., Chopineau, J., Kieboom, A. P. G. & Klivanov, A. M. (1988) *J. Am. Chem. Soc.* **110**, 584–589.
- Wong, C.-H. & Wang, K.-T. (1991) *Experientia* **47**, 1123–1129.
- Chatterjee, S. & Russell, A. J. (1992) *Biotechnol. Bioeng.* **40**, 1069–1077.